

Shadows

CS425: Computer Graphics I

Khairi Reda

Overview

- Shadow projection (planar)
- Shadow Mapping
- Shadow Volume
- Shadow Accumulation

Shadows



Shadows



Shadows



Shadows



Shadows



Shadows



Importance of shadows

- Add realism to the scene.
- Shape, volume of the object.
- Position of light source.
- Depth perception.

Importance of shadows

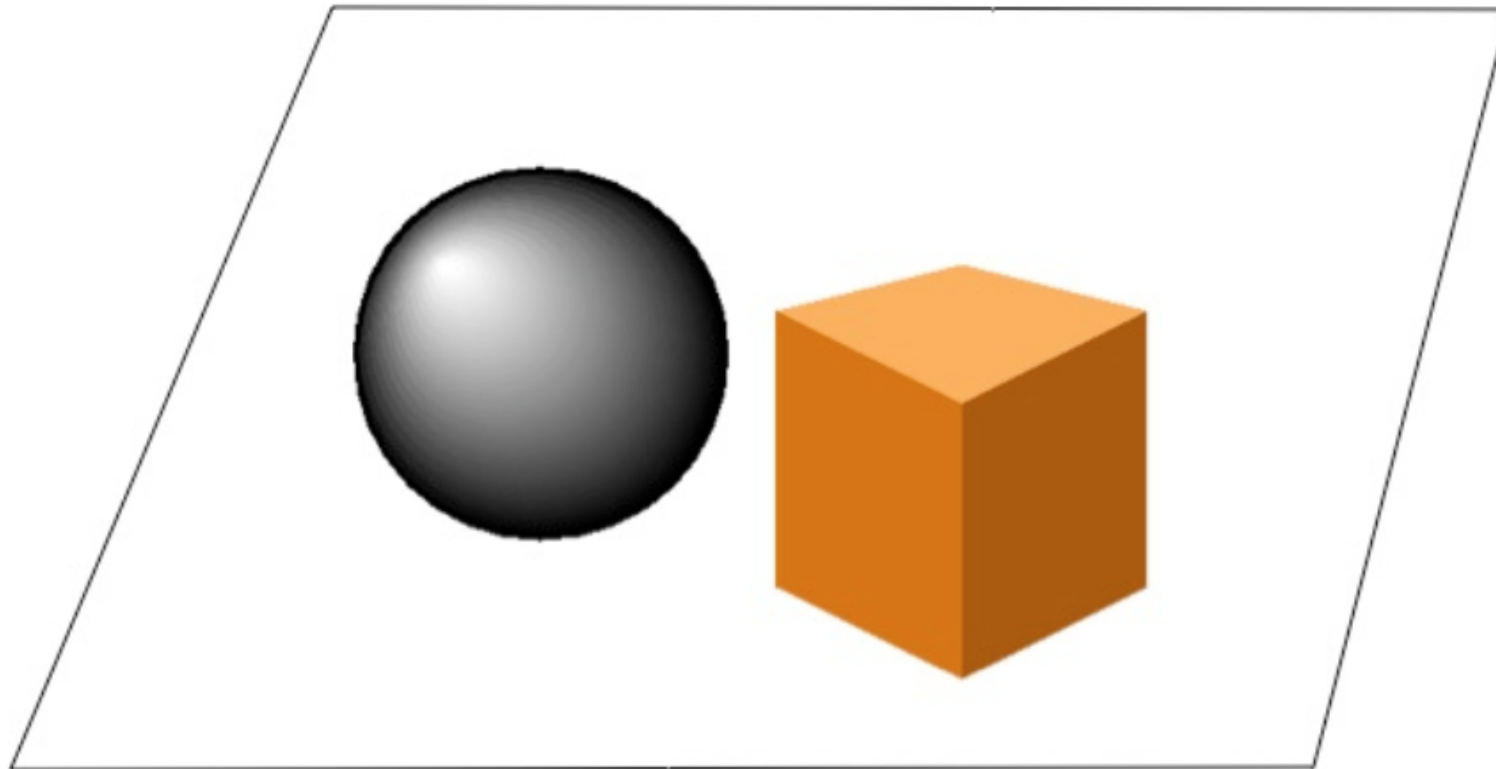

Importance of shadows

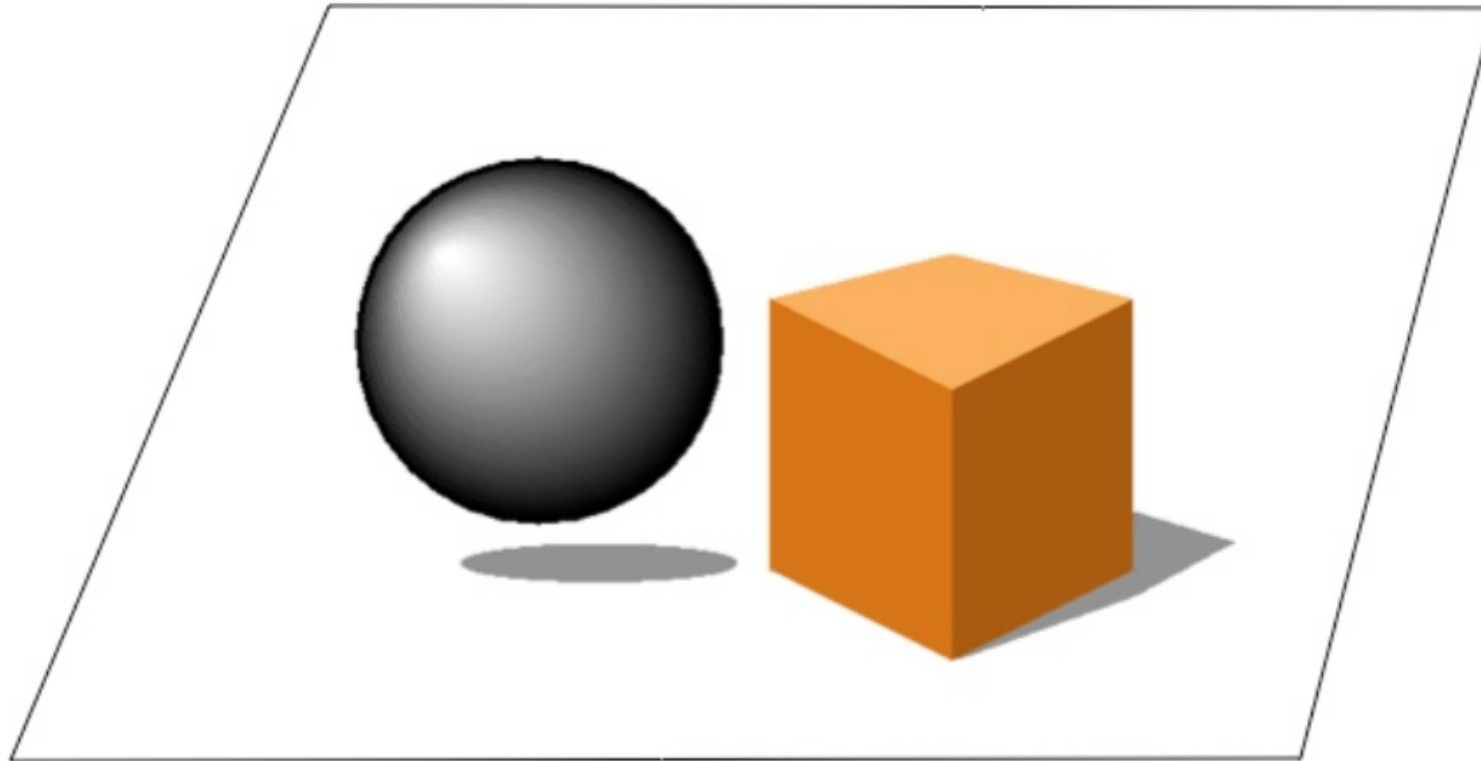

Importance of shadows

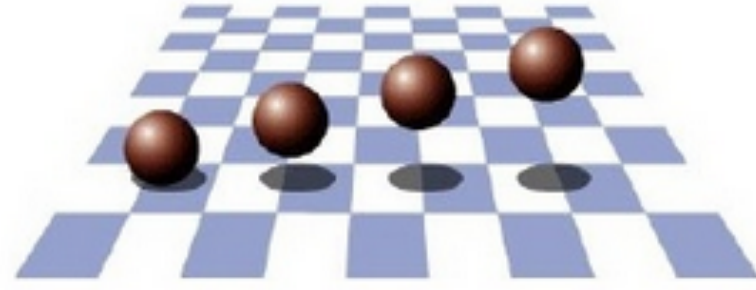
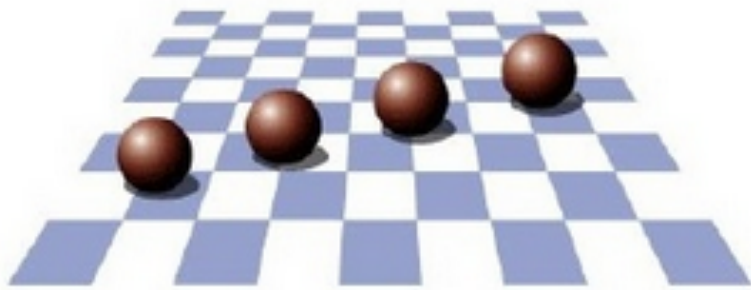

Shadow components

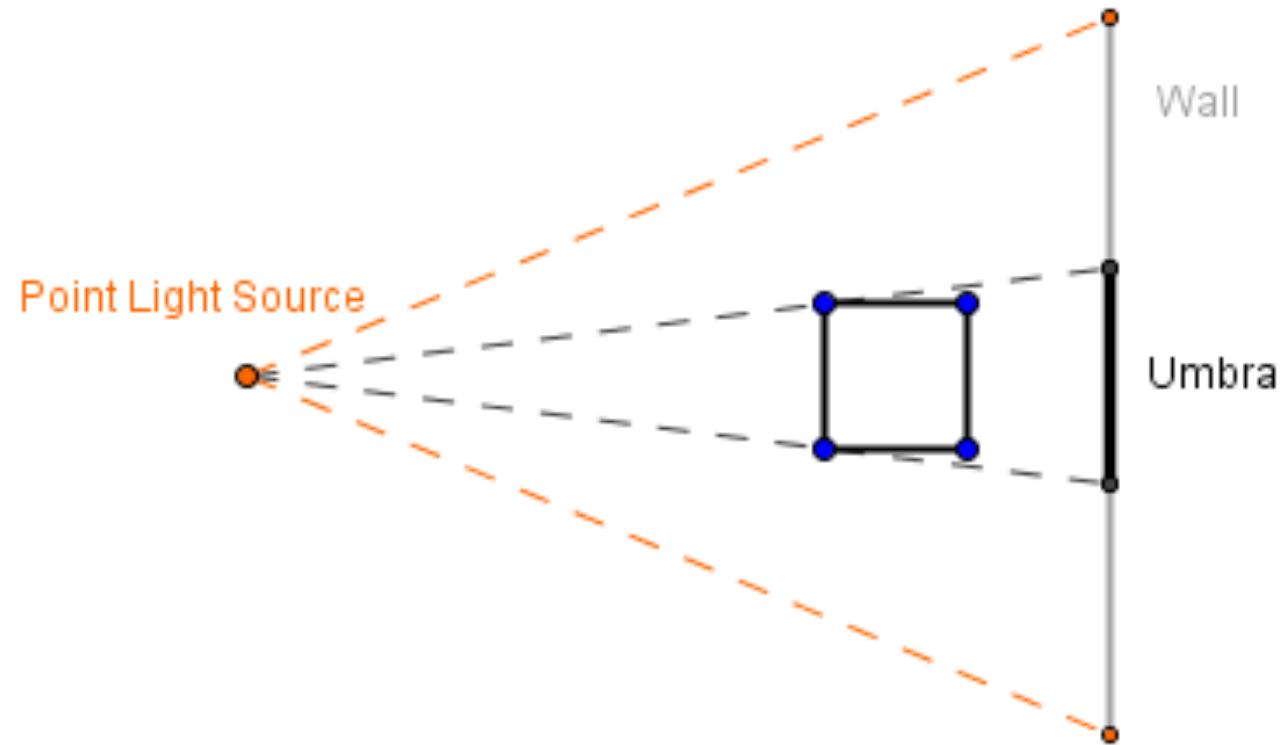

Shadow components

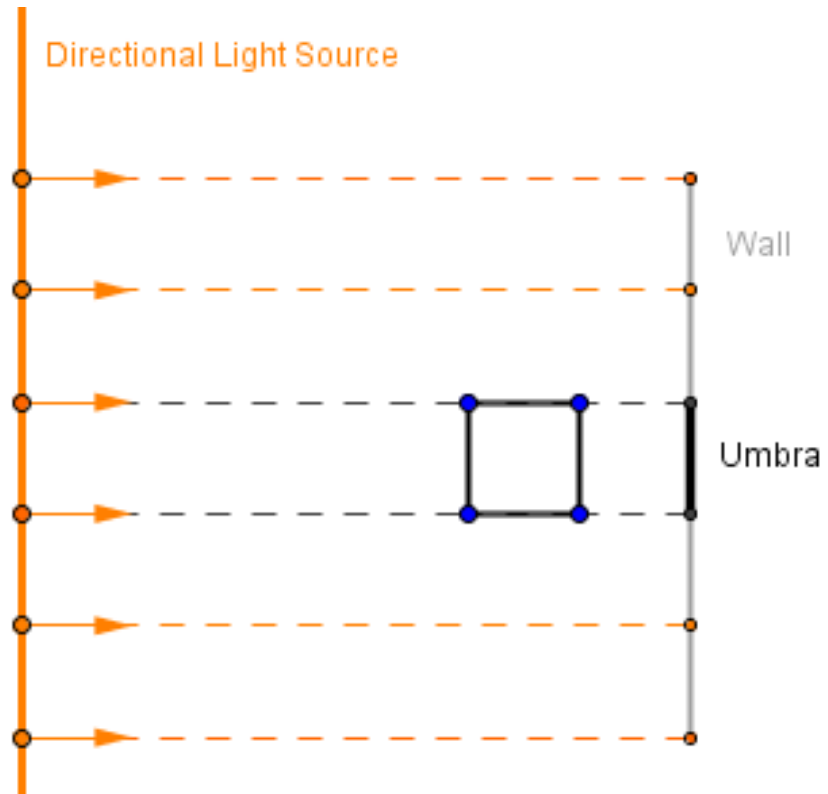

Shadow components

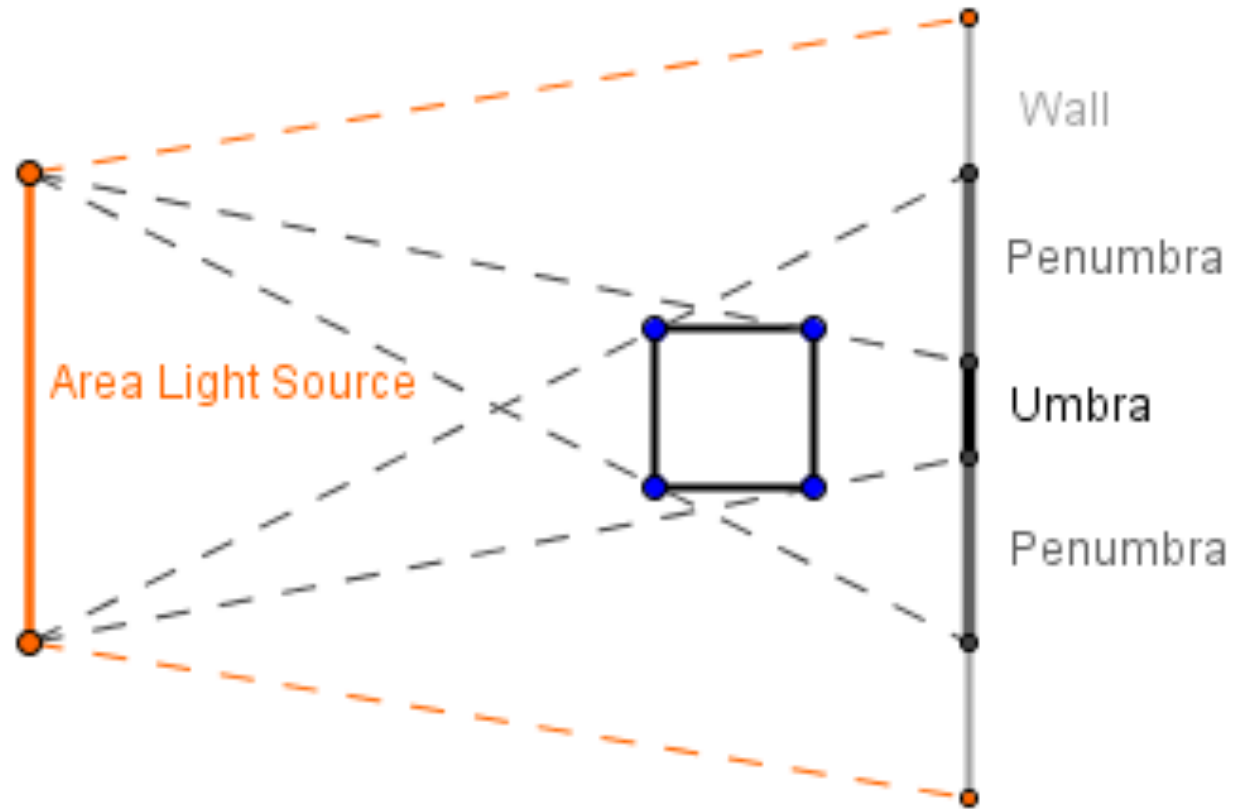

Goal

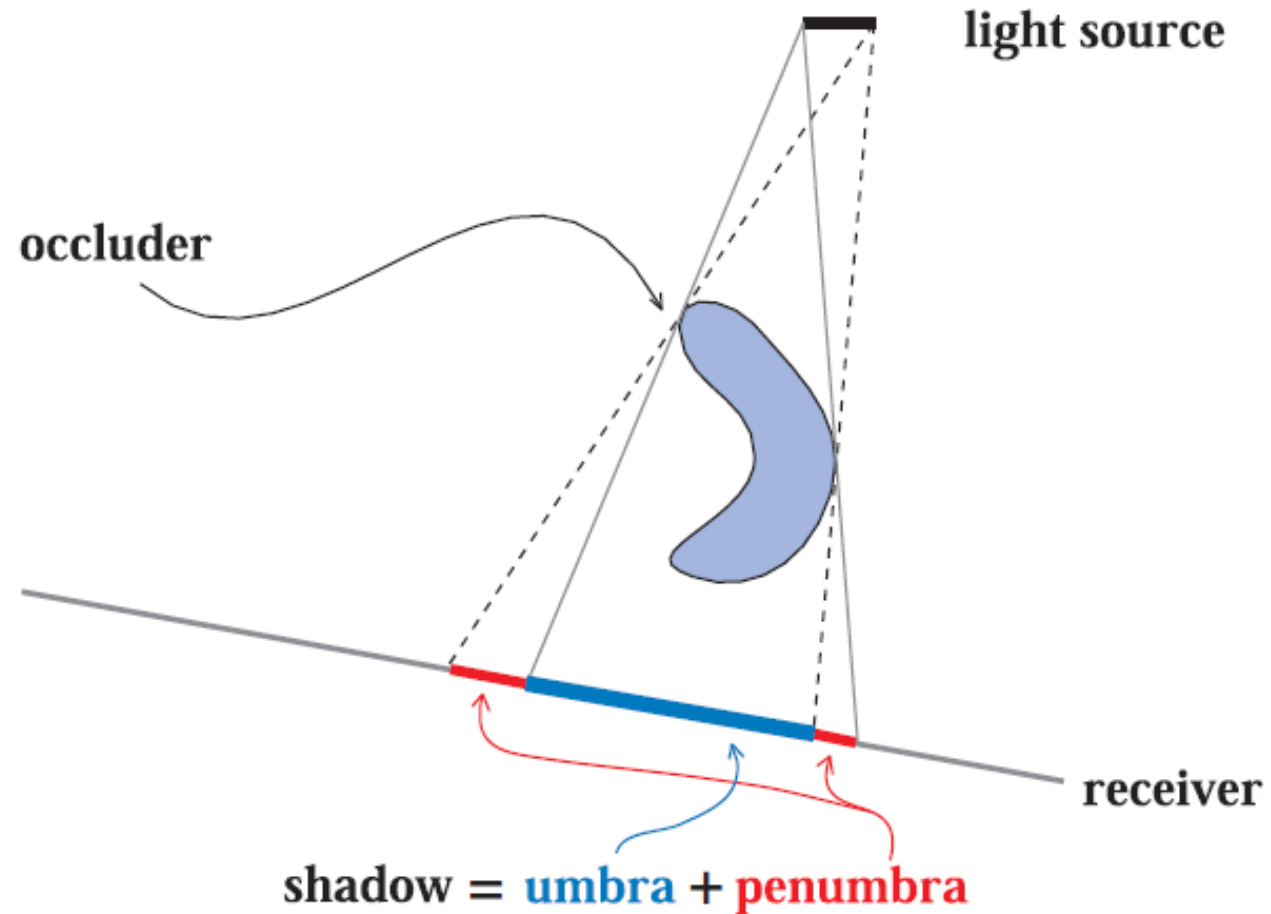

Planar shadows

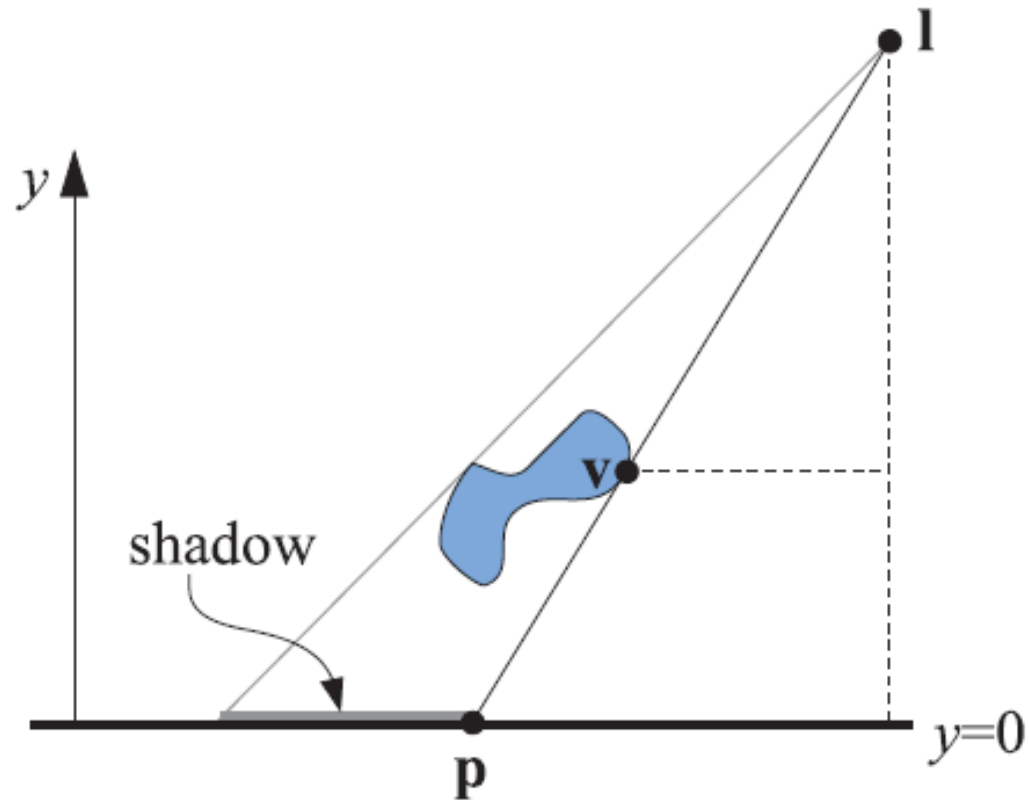

p?

Planar shadows

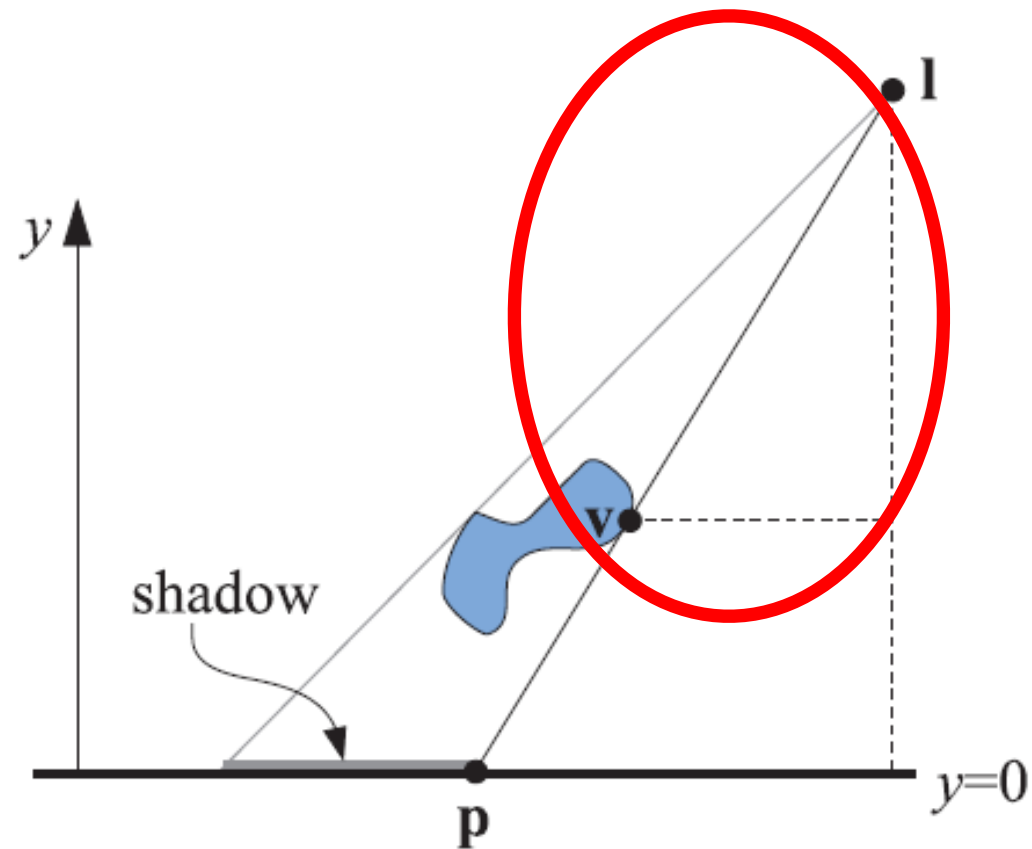

Planar shadows

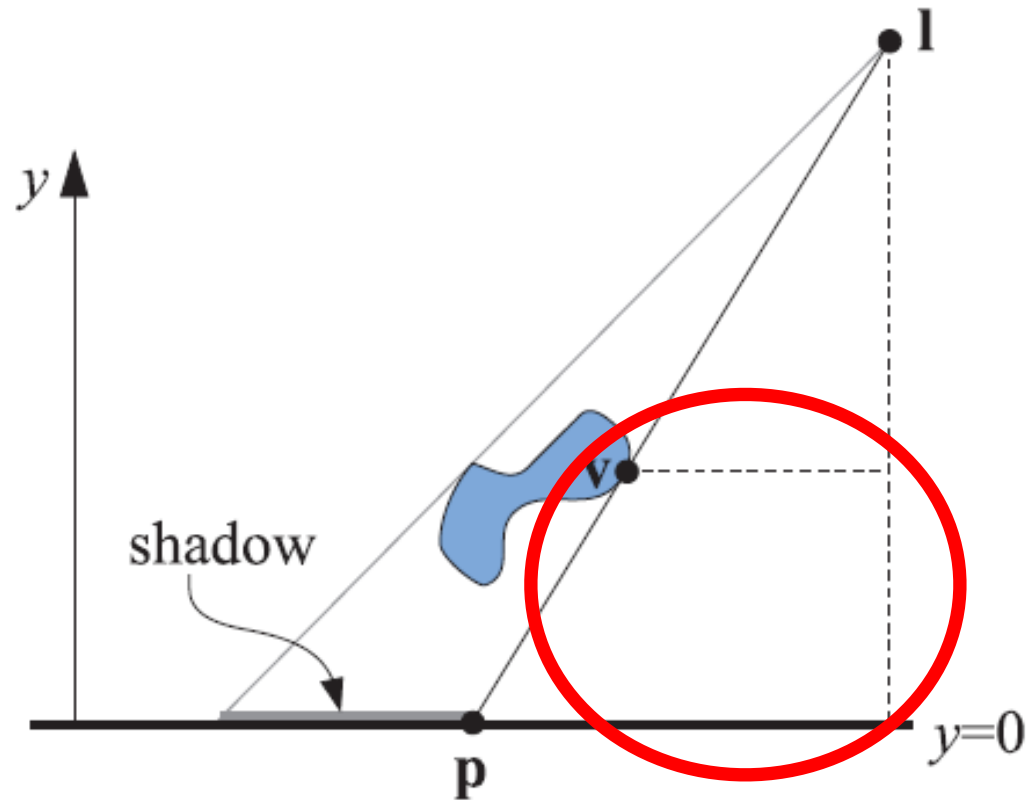

Planar shadows

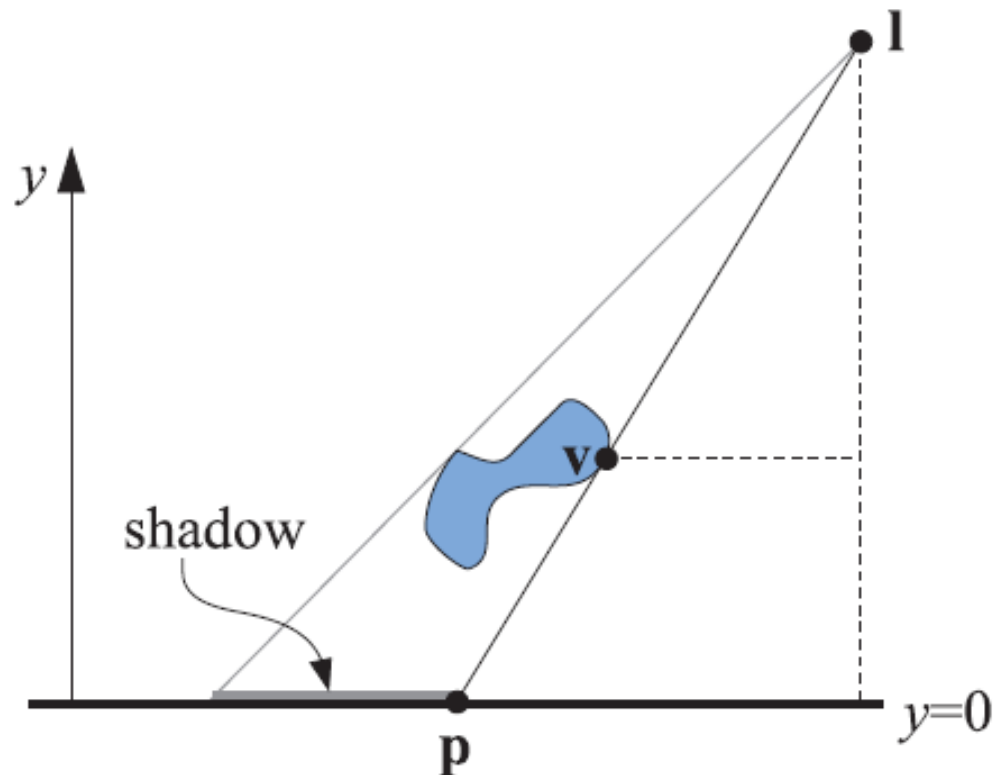

$$\frac{p_x - l_x}{v_x - l_x} = \frac{l_y}{l_y - v_y}$$

$$p_x = \frac{l_y v_x - l_x v_y}{l_y - v_y}$$

Planar shadows

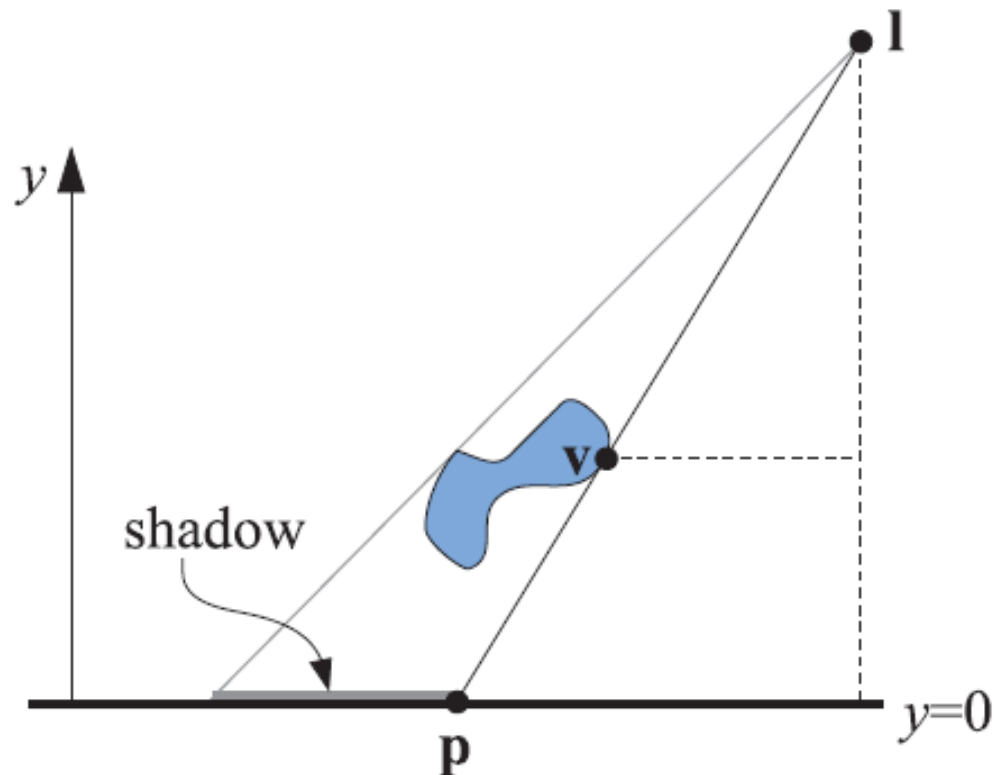

$$Mv = p$$

$$M = \begin{bmatrix} l_y & -l_x & 0 & 0 \\ 0 & 0 & 0 & 0 \\ 0 & -l_z & l_y & 0 \\ 0 & -1 & 0 & l_y \end{bmatrix}$$

Planar Shadows

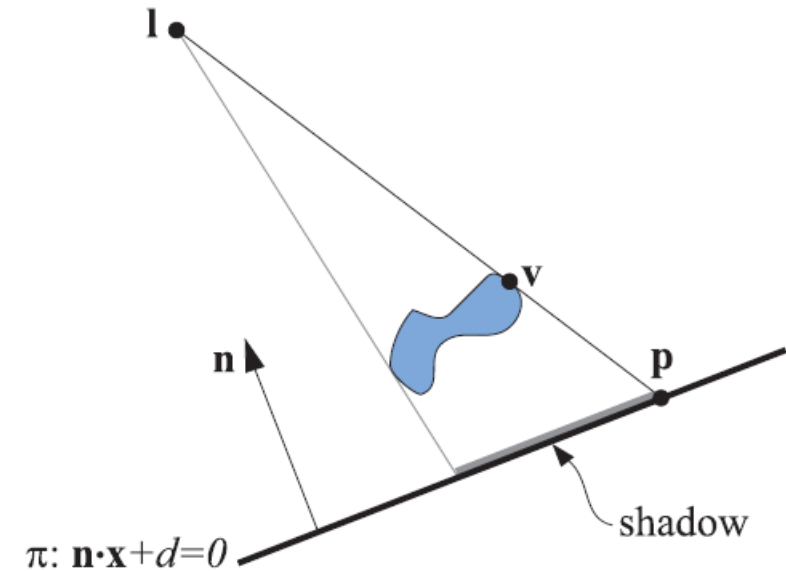

$$\mathbf{M} = \begin{bmatrix} \mathbf{n} \cdot \mathbf{l} + d - l_x n_x & -l_x n_y & -l_x n_z & -l_x d \\ -l_y n_x & \mathbf{n} \cdot \mathbf{l} + d - l_y n_y & -l_y n_z & -l_y d \\ -l_z n_x & -l_z n_y & \mathbf{n} \cdot \mathbf{l} + d - l_z n_z & -l_z d \\ n_x & n_y & n_z & \mathbf{n} \cdot \mathbf{l} \end{bmatrix}$$

Planar shadow: steps

- Render receiving plane
- Render occluder, projecting with matrix M
- Render occluder

Planar shadows: example

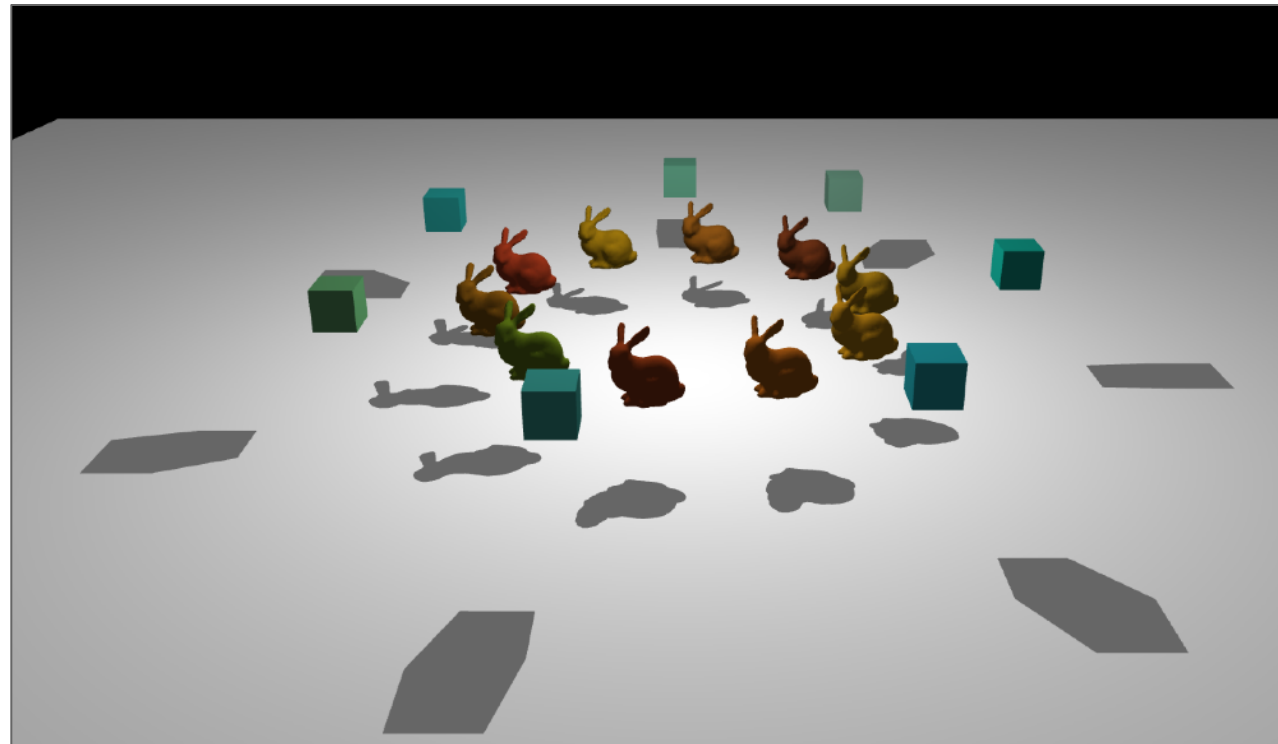

https://erkaman.github.io/planar_proj_shadows/planar_proj_shadows.html

Planar Shadows: shortcomings

- Z-fighting:
 - Precision problem between receiving plane and occlude.
 - Use polygon offset (`glPolygonOffset`).
- Restricted to planar objects.
- Anti-shadows.

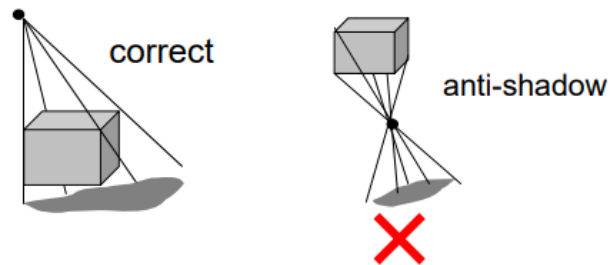

Shadow maps

- Image-space shadow determination.
- Leverages GPU hardware:
 - Depth buffering + texture mapping
- Two steps algorithm:
 - First, render scene from light's point of view.
 - Second, render scene from eye's point of view.

Shadow maps

- First step:
 - Render from light's point of view:
 - Result stored in a depth buffer, as a shadow map.
 - A **2D texture** indicating the depth of the closest pixel to the light.
 - Shadow map is used in the second step.

Shadow maps

- Second step:
 - Render from eye's point of view:
 - For each fragment, determine its position in the light space.
 - Compare depth value at light position with the depth value from shadow map.
 - Two values:
 - A: z value of fragment in light space.
 - B: z value of fragment in shadow map.
 - $B > A$: shadow
 - $A > B$: no shadow

Shadow maps

ORTHOGRAPHIC PROJECTION

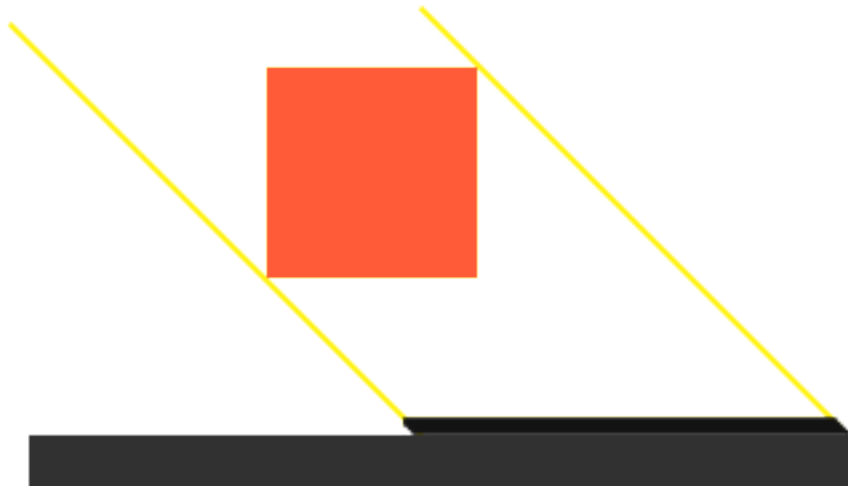

PERSPECTIVE PROJECTION

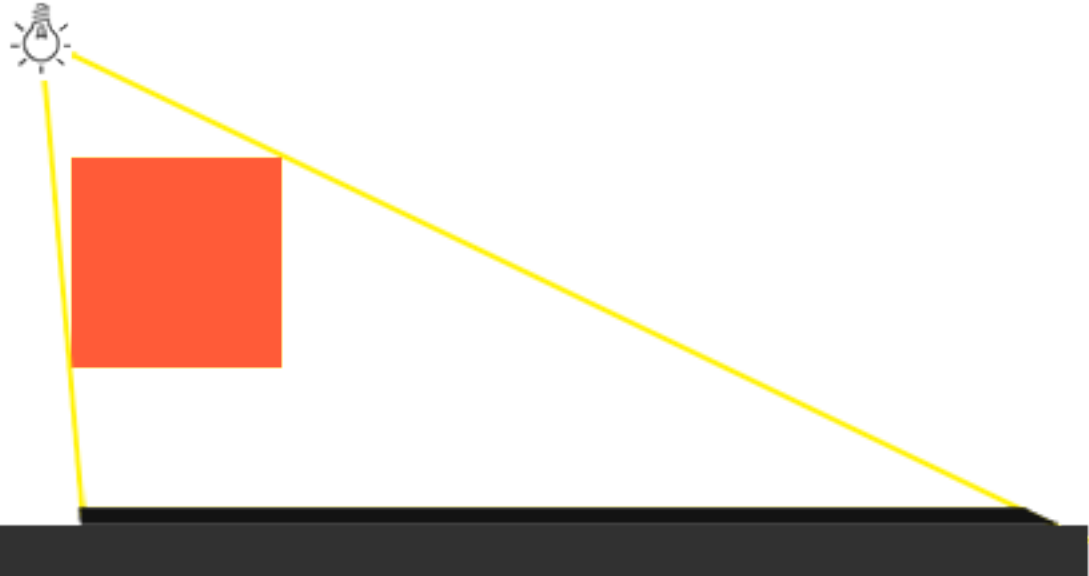

Shadow test

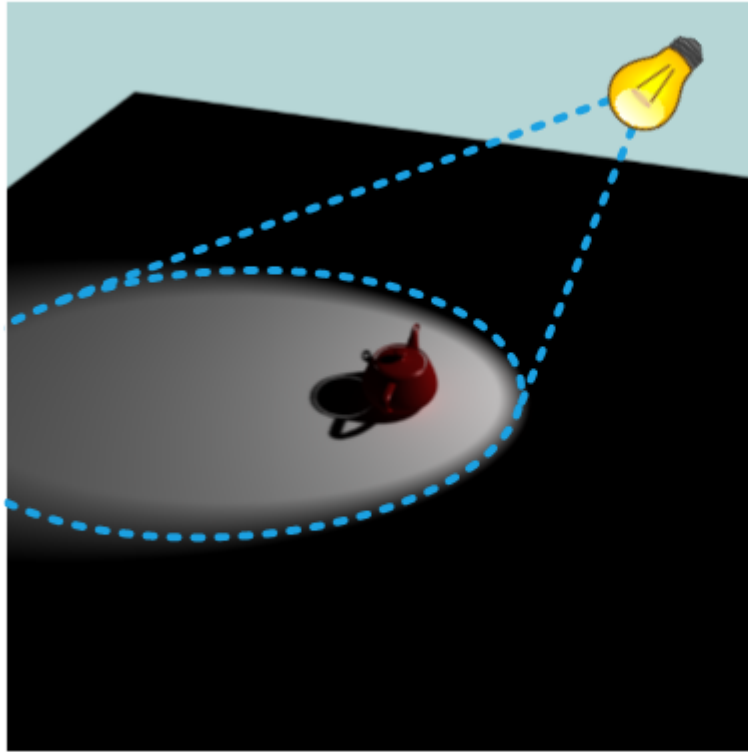

Shadow test

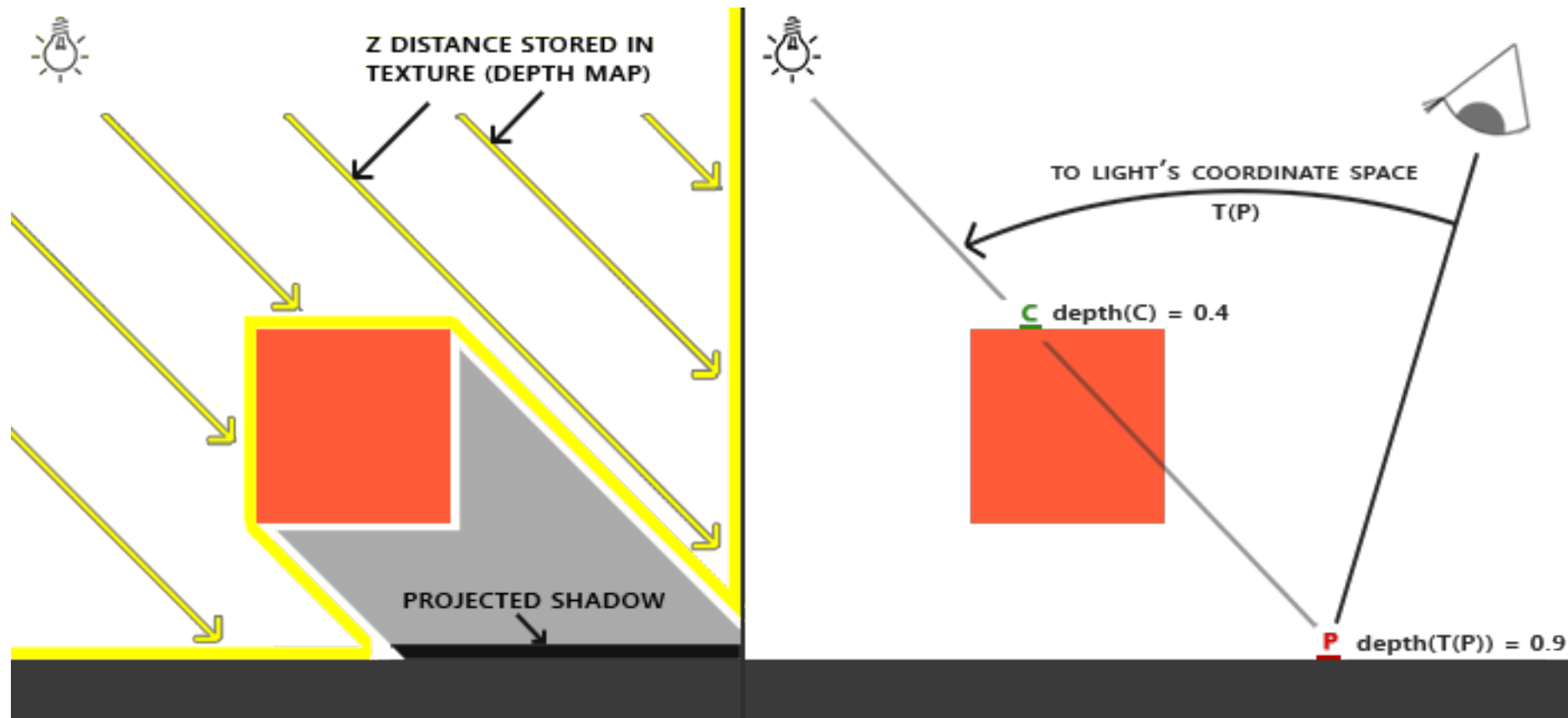

Shadow maps + GL

1. Creating shadow map framebuffer for rendering shadow map:

```
unsigned int depthMapFBO;  
glGenFramebuffers(1, &depthMapFBO);
```

2. Creating shadow map texture with size 1024

```
const unsigned int SHADOW_WIDTH = 1024, SHADOW_HEIGHT = 1024;  
  
unsigned int depthMap;  
glGenTextures(1, &depthMap);  
glBindTexture(GL_TEXTURE_2D, depthMap);  
glTexImage2D(GL_TEXTURE_2D, 0, GL_DEPTH_COMPONENT,  
             SHADOW_WIDTH, SHADOW_HEIGHT, 0, GL_DEPTH_COMPONENT, GL_FLOAT, NULL);  
glTexParameteri(GL_TEXTURE_2D, GL_TEXTURE_MIN_FILTER, GL_NEAREST);  
glTexParameteri(GL_TEXTURE_2D, GL_TEXTURE_MAG_FILTER, GL_NEAREST);  
glTexParameteri(GL_TEXTURE_2D, GL_TEXTURE_WRAP_S, GL_REPEAT);  
glTexParameteri(GL_TEXTURE_2D, GL_TEXTURE_WRAP_T, GL_REPEAT);
```

Shadow maps + GL

3. Attach texture to framebuffer

```
unsigned int depthMapFBO;  
glGenFramebuffers(1, &depthMapFBO);
```

```
glBindFramebuffer(GL_FRAMEBUFFER, depthMapFBO);  
glFramebufferTexture2D(GL_FRAMEBUFFER, GL_DEPTH_ATTACHMENT, GL_TEXTURE_2D, depthMap, 0);  
glDrawBuffer(GL_NONE);  
glReadBuffer(GL_NONE);  
glBindFramebuffer(GL_FRAMEBUFFER, 0);
```

Shadow maps + GL

4. Render scene twice

```
// 1. first render to depth map
glViewport(0, 0, SHADOW_WIDTH, SHADOW_HEIGHT);
glBindFramebuffer(GL_FRAMEBUFFER, depthMapFBO);
    glClear(GL_DEPTH_BUFFER_BIT);
    ConfigureShaderAndMatrices();
    RenderScene();
glBindFramebuffer(GL_FRAMEBUFFER, 0);
// 2. then render scene as normal with shadow mapping (using depth
    map)
glViewport(0, 0, SCR_WIDTH, SCR_HEIGHT);
glClear(GL_COLOR_BUFFER_BIT | GL_DEPTH_BUFFER_BIT);
ConfigureShaderAndMatrices();
glBindTexture(GL_TEXTURE_2D, depthMap);
RenderScene();
```

Shadow maps + GL

4. Shadow test: vertex shader

```
#version 330 core
layout (location = 0) in vec3 aPos;
layout (location = 1) in vec3 aNormal;
layout (location = 2) in vec2 aTexCoords;

out VS_OUT {
    vec3 FragPos;
    vec3 Normal;
    vec2 TexCoords;
    vec4 FragPosLightSpace;
} vs_out;

uniform mat4 projection;
uniform mat4 view;
uniform mat4 model;
uniform mat4 lightSpaceMatrix;

void main()
{
    vs_out.FragPos = vec3(model * vec4(aPos, 1.0));
    vs_out.Normal = transpose(inverse(mat3(model))) * aNormal;
    vs_out.TexCoords = aTexCoords;
    vs_out.FragPosLightSpace = lightSpaceMatrix * vec4(vs_out.FragPos, 1.0);
    gl_Position = projection * view * vec4(vs_out.FragPos, 1.0);
}
```

Shadow maps + GL

4. Shadow test: fragment shader

```
float ShadowCalculation(vec4 fragPosLightSpace)
{
    // perform perspective divide
    vec3 projCoords = fragPosLightSpace.xyz / fragPosLightSpace.w;
    [...]
}
```

```
projCoords = projCoords * 0.5 + 0.5;
```

```
float closestDepth = texture(shadowMap, projCoords.xy).r;
```

```
float currentDepth = projCoords.z;
float shadow = currentDepth > closestDepth ? 1.0 : 0.0;
```

Shadow map result



Shadow maps

- Advantages:
 - Fast
 - Simple depth map comparison

Shadow acne

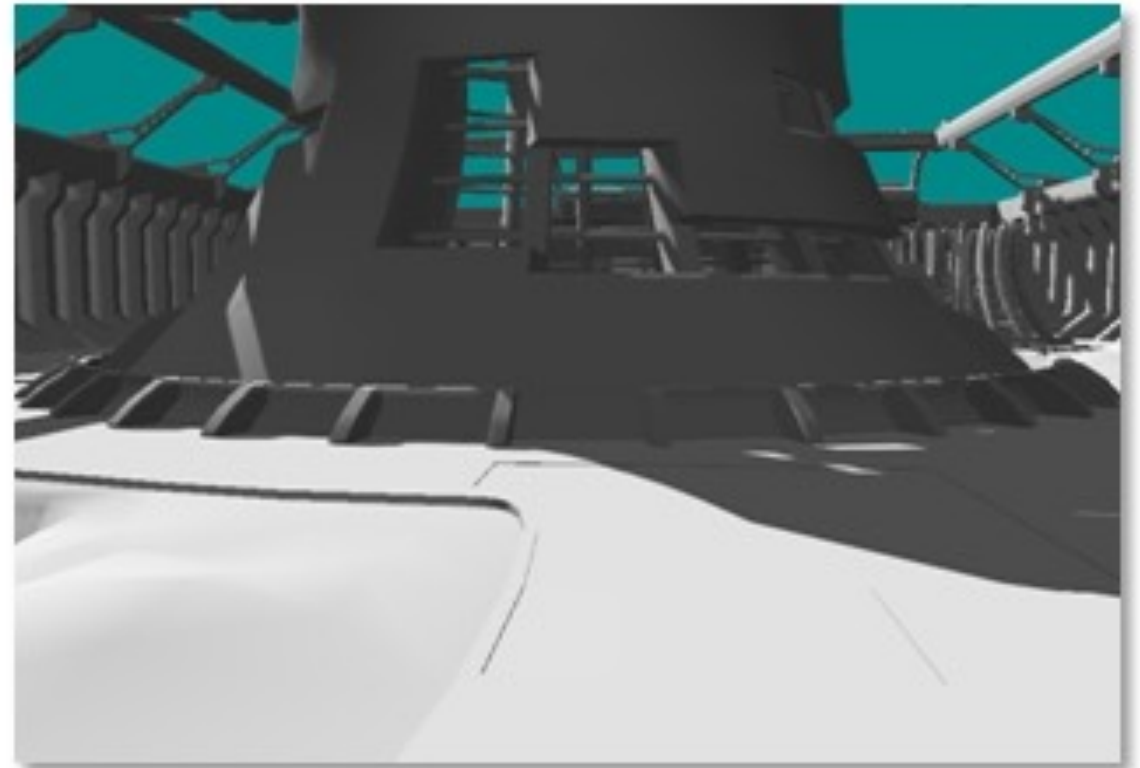
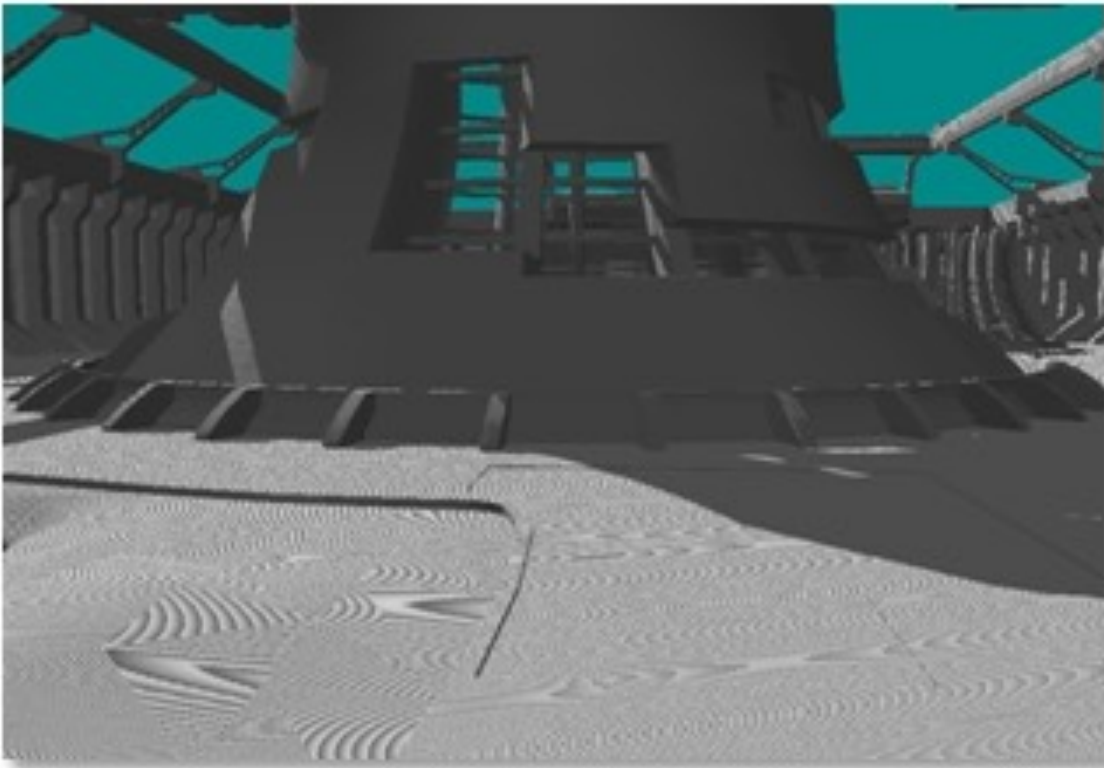

Shadow acne

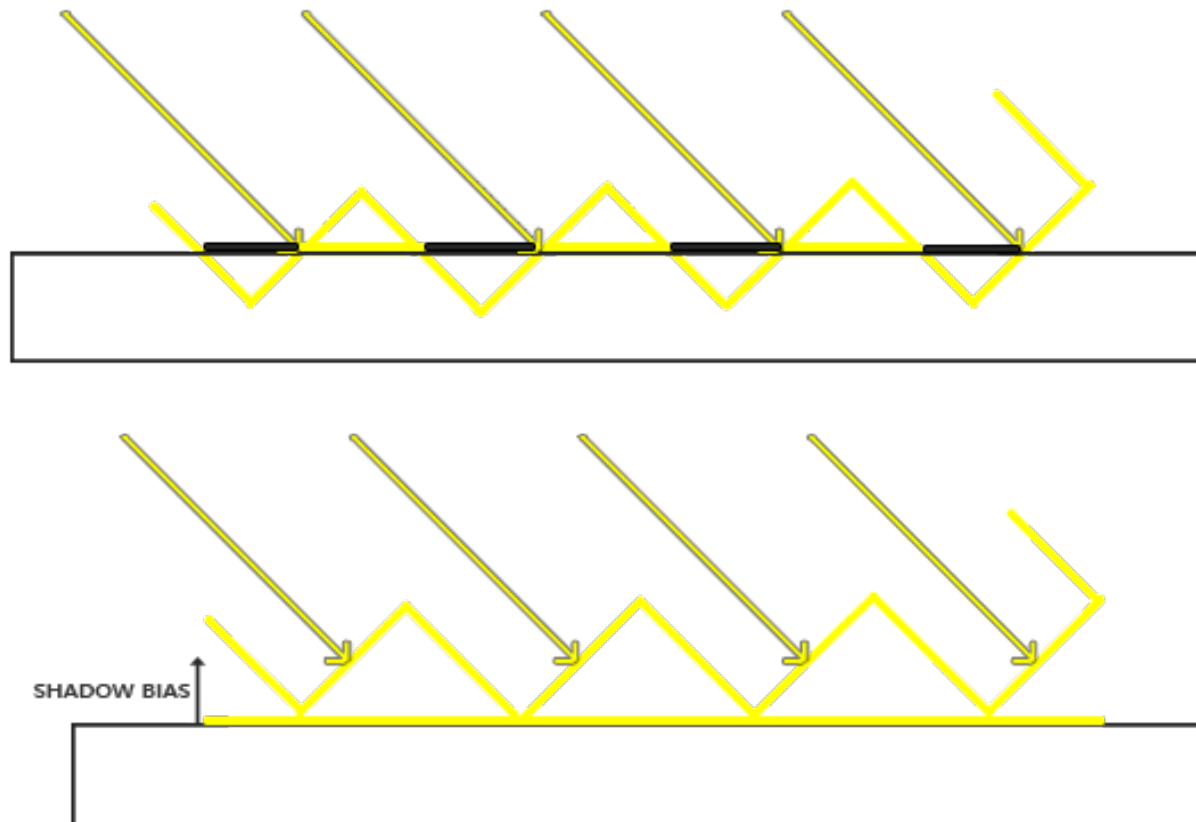

Peter panning



Shadow aliasing

- Finite shadow map resolution: pixelized shadows.
- Large scenes require high shadow map resolution, and a tight projection.

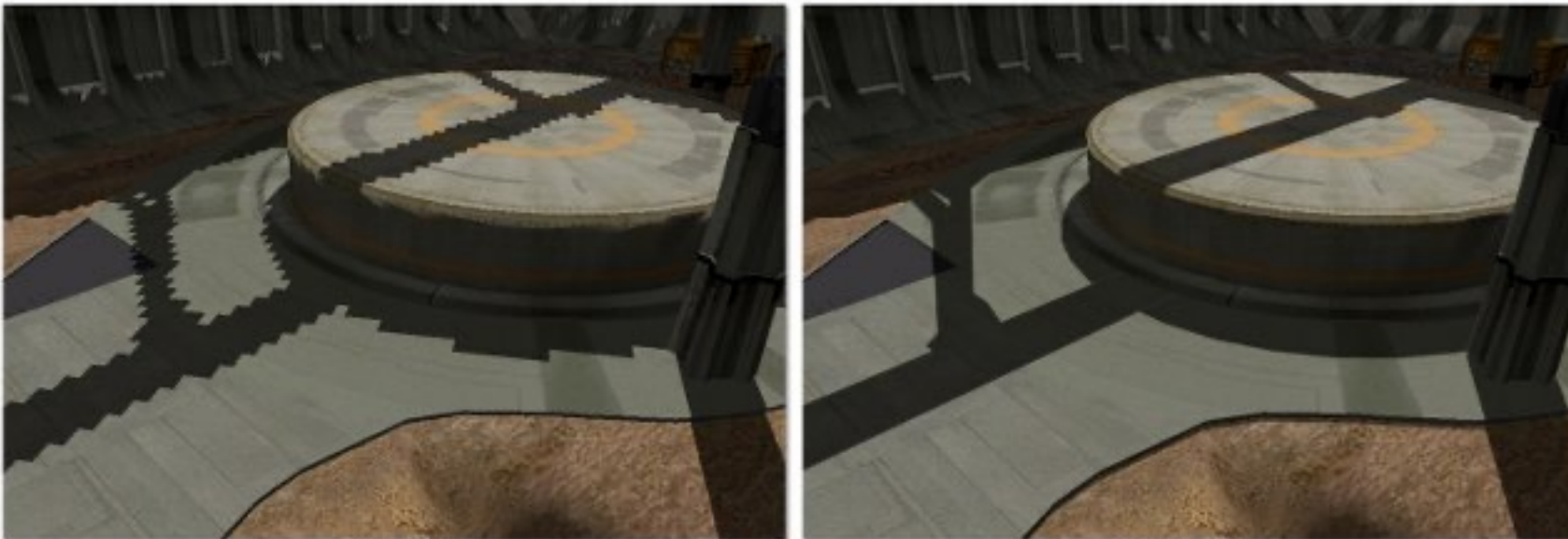

Shadow aliasing

- Finite shadow map resolution: pixelized shadows.
- Large scenes require high shadow map resolution, and a tight projection.

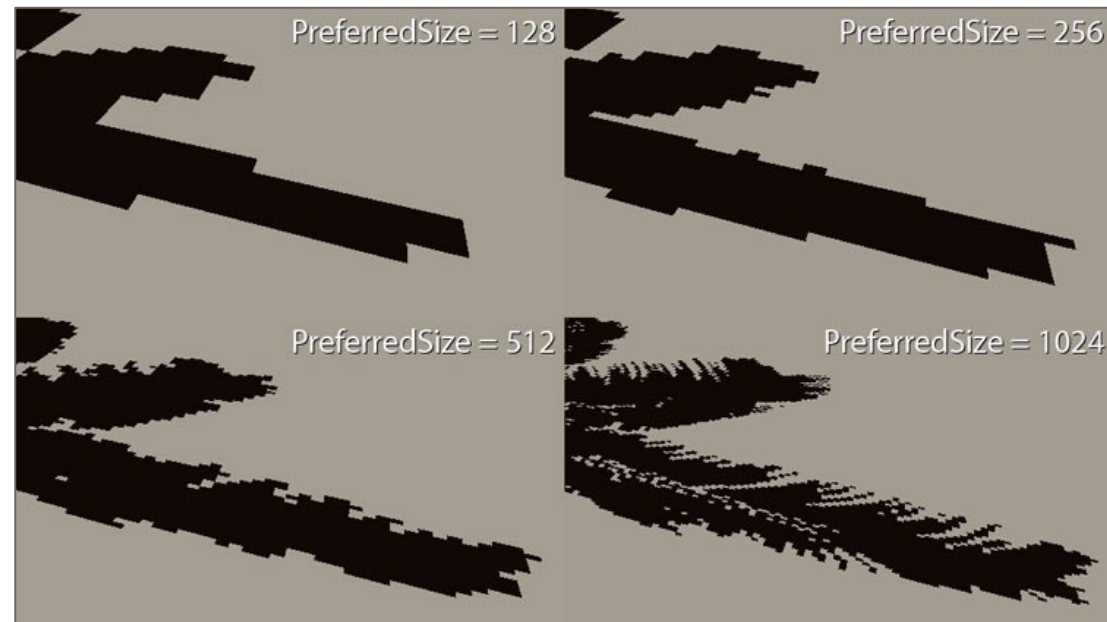

DigitalRune

Shadow aliasing

- Calculate a tight projection. How?

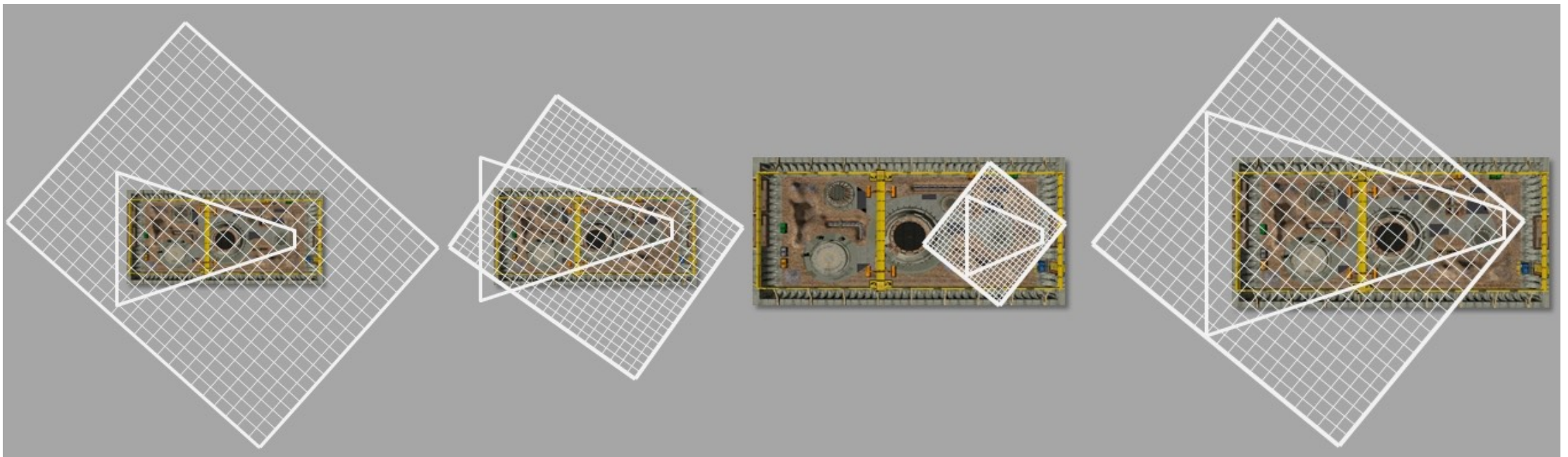

Computing optimal projection

- Calculate 8 corners of view frustum in light space.
- 6 planes: 4 sides, near, far.
- Clip scene's bounds against 4 side planes.
- Smallest and largest z-values of clipped boundaries represent the near and far plan, respectively.

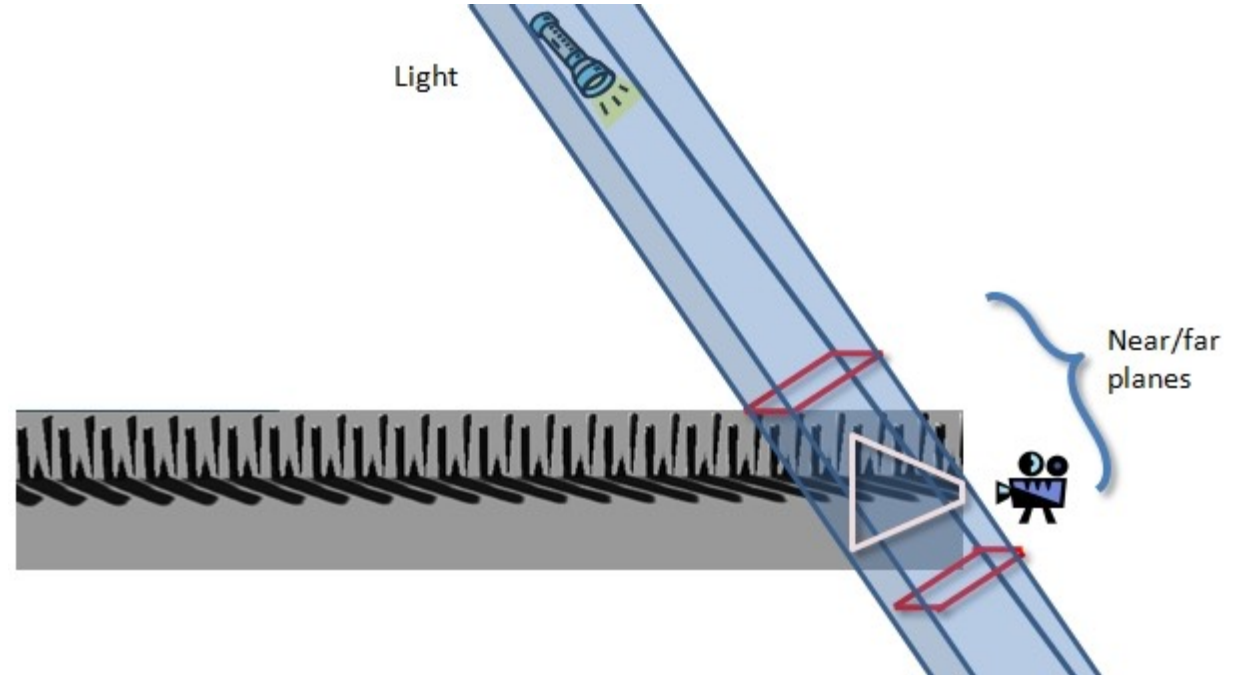

Shadow aliasing

- Solution: sample from more than once from shadow map

```
float shadow = 0.0;
vec2 texelSize = 1.0 / textureSize(shadowMap, 0);
for(int x = -1; x <= 1; ++x)
{
    for(int y = -1; y <= 1; ++y)
    {
        float pcfDepth = texture(shadowMap, projCoords.xy + vec2(x
, y) * texelSize).r;
        shadow += currentDepth -
bias > pcfDepth ? 1.0 : 0.0;
    }
}
shadow /= 9.0;
```

Shadow aliasing

- Solution: sample from more than once from shadow map.

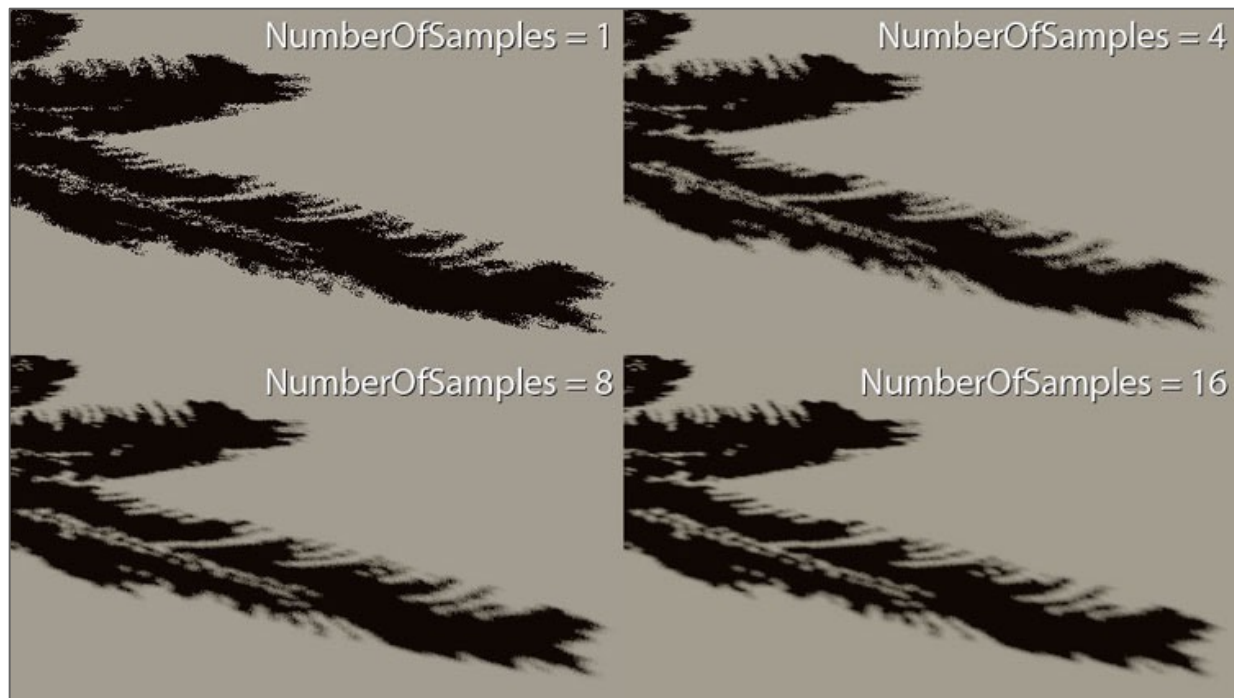

DigitalRune

Shadow maps

Improving Shadow maps

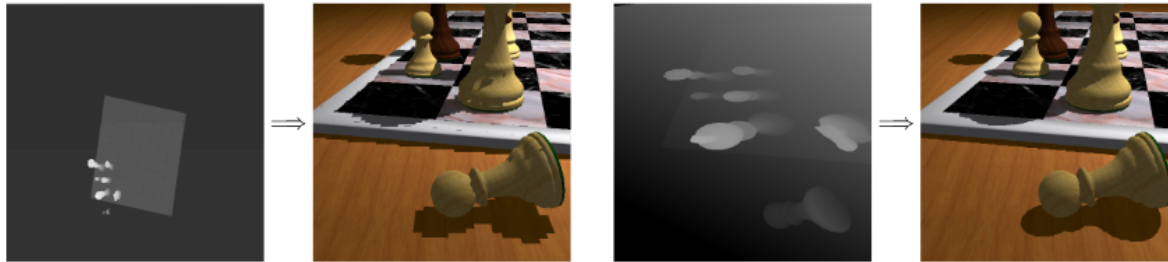

Perspective Shadow Maps
[Stamminger and Drettakis, 2002]

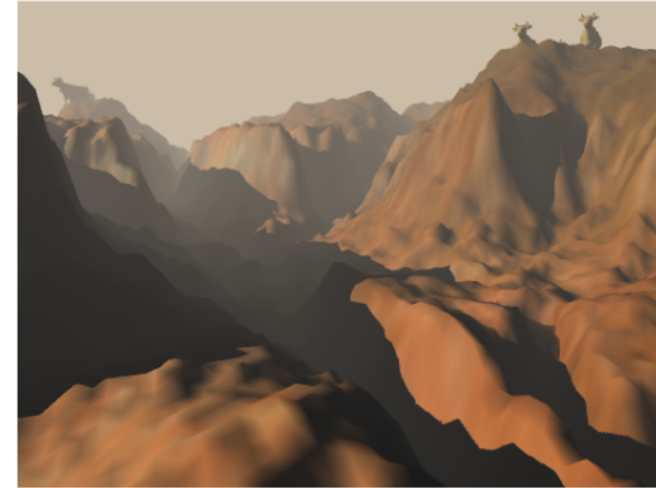

Figure 3-1. Large scale terrain rendering with 4-splits CSM

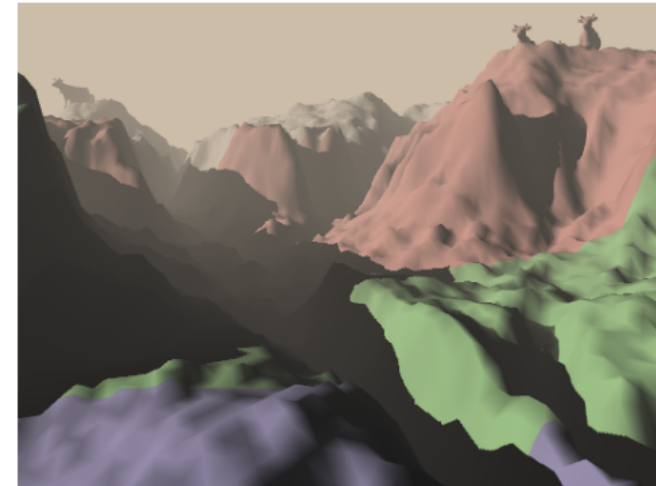

Figure 3-2. Texture look ups from different shadow maps are highlighted

Cascaded Shadow Maps [Dimitrov, 2007]

Shadow volume



Silhouette detection

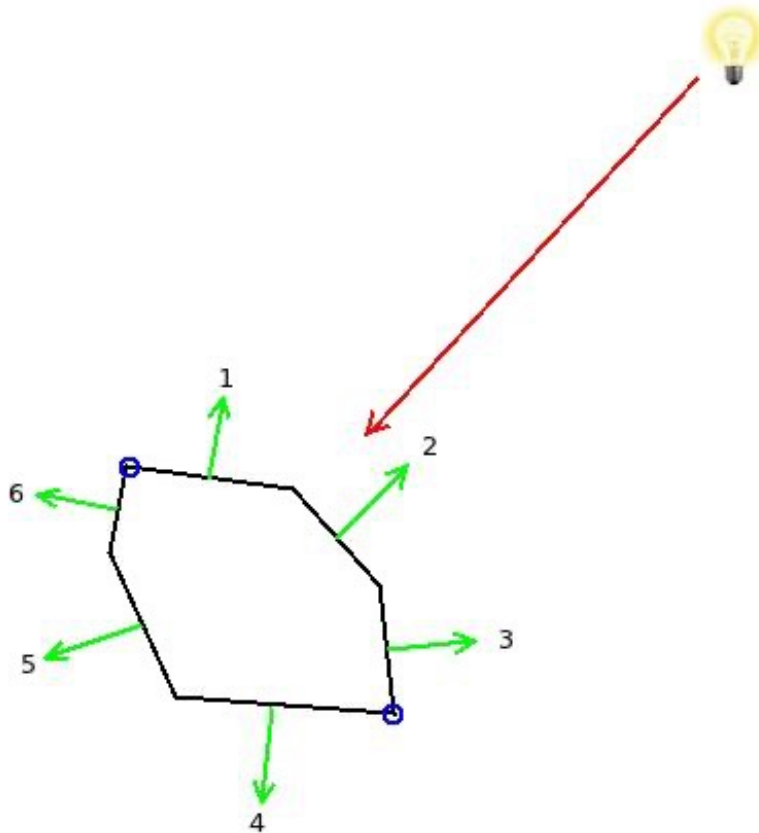

Silhouette:

- If one neighboring edge is facing the light, the other not.

Silhouette detection

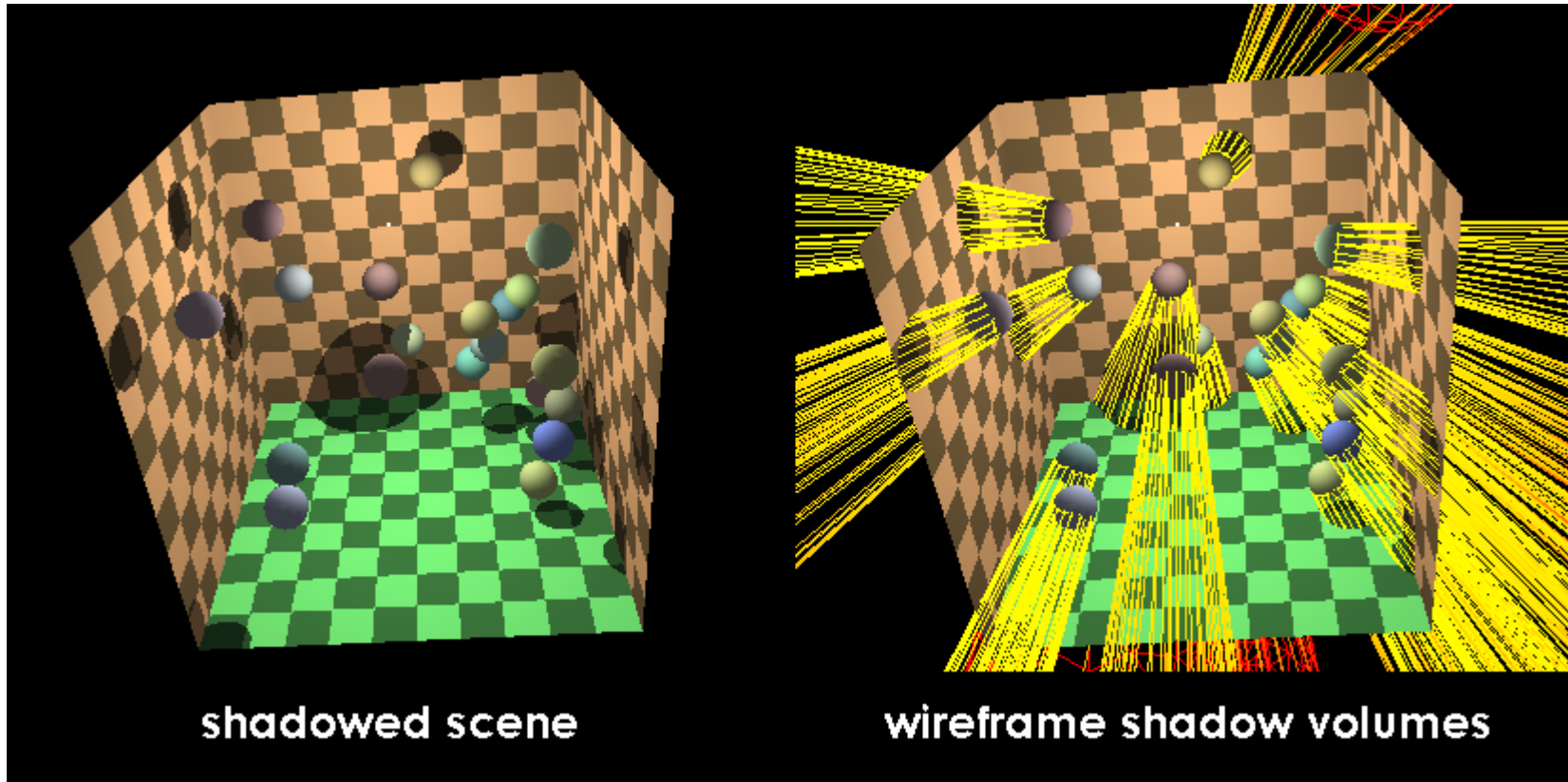

Silhouette detection

How to find the edges?

Geometry shader

```
#version 330

layout (location = 0) in vec3 Position;
layout (location = 1) in vec2 TexCoord;
layout (location = 2) in vec3 Normal;

out vec3 WorldPos0;

uniform mat4 gWVP;
uniform mat4 gWorld;

void main()
{
    vec4 PosL = vec4(Position, 1.0);
    gl_Position = gWVP * PosL;
    WorldPos0 = (gWorld * PosL).xyz;
}
```

Vertex Shader

Silhouette detection

How to find the edges?

Geometry shader

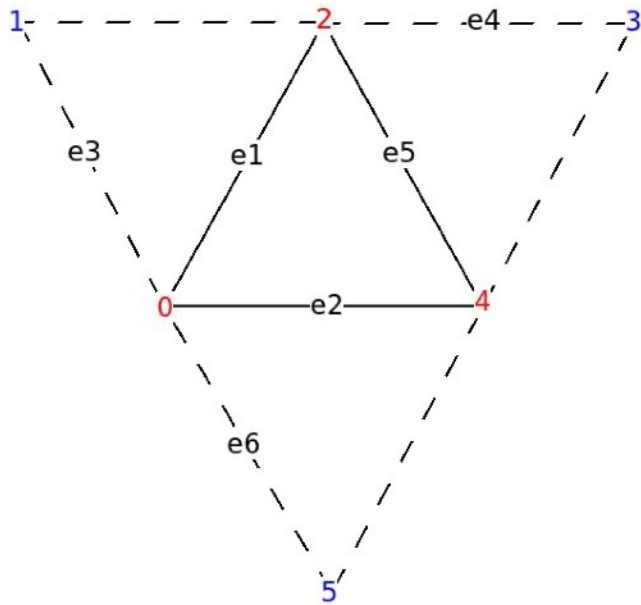

```
#version 330

layout (triangles_adjacency) in;
layout (line_strip, max_vertices = 6) out;

in vec3 WorldPos0[];

uniform vec3 gLightPos;

void main()
{
    vec3 e1 = WorldPos0[2] - WorldPos0[0];
    vec3 e2 = WorldPos0[4] - WorldPos0[0];
    vec3 e3 = WorldPos0[1] - WorldPos0[0];
    vec3 e4 = WorldPos0[3] - WorldPos0[2];
    vec3 e5 = WorldPos0[4] - WorldPos0[2];
    vec3 e6 = WorldPos0[5] - WorldPos0[0];

    vec3 Normal = cross(e1,e2);
    vec3 LightDir = gLightPos - WorldPos0[0];

    if (dot(Normal, LightDir) > 0.00001) {
        Normal = cross(e3,e1);

        if (dot(Normal, LightDir) <= 0) {
            // Silhouette!!!
        }

        Normal = cross(e4,e5);
        LightDir = gLightPos - WorldPos0[2];

        if (dot(Normal, LightDir) <=0) {
            // Silhouette!!!
        }

        Normal = cross(e2,e6);
        LightDir = gLightPos - WorldPos0[4];

        if (dot(Normal, LightDir) <= 0) {
            // Silhouette!!!
        }
    }
}
```

Projection

$$\begin{bmatrix} 1 & 0 & 0 & 0 \\ 0 & 1 & 0 & 0 \\ 0 & 0 & 1 & 0 \\ 0 & 0 & 1 & 0 \end{bmatrix} \begin{bmatrix} 2 \\ 3 \\ 4 \\ 1 \end{bmatrix} = \begin{bmatrix} 2 \\ 3 \\ 4 \\ 4 \end{bmatrix}$$

$$\frac{(2,3,4)}{4} = (0.5, 0.75, 1)$$

$$\frac{(2,3,4)}{0} = (\infty, \infty, \infty)$$

Projection

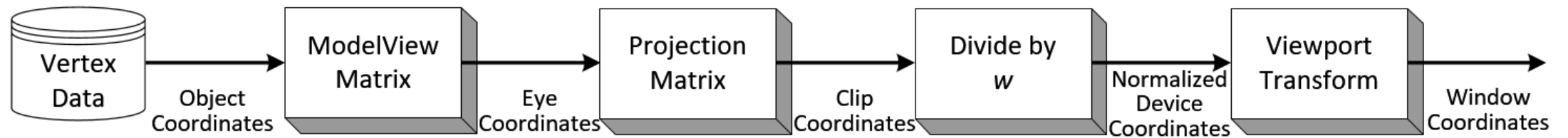

Silhouette detection

How to create volume?

Geometry shader

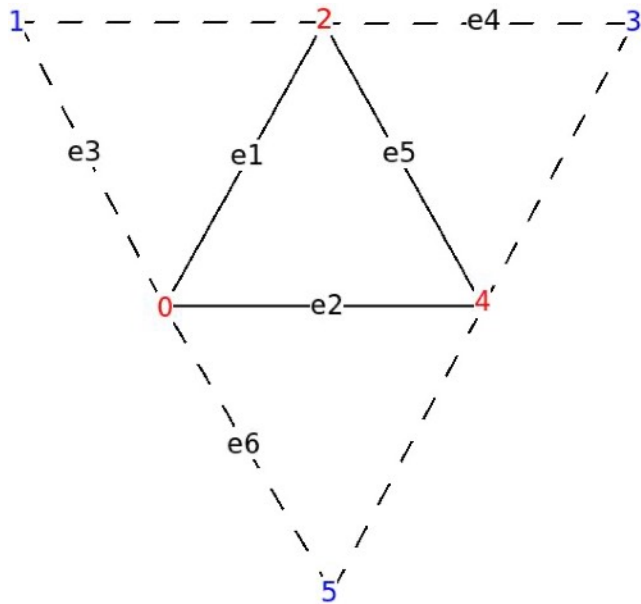

```
// Emit a quad using a triangle strip
void EmitQuad(vec3 StartVertex, vec3 EndVertex)
{
    // Vertex #1: the starting vertex (just a tiny bit below the original edge)
    vec3 LightDir = normalize(StartVertex - gLightPos);
    gl_Position = gWVP * vec4((StartVertex + LightDir * EPSILON), 1.0);
    EmitVertex();

    // Vertex #2: the starting vertex projected to infinity
    gl_Position = gWVP * vec4(LightDir, 0.0);
    EmitVertex();

    // Vertex #3: the ending vertex (just a tiny bit below the original edge)
    LightDir = normalize(EndVertex - gLightPos);
    gl_Position = gWVP * vec4((EndVertex + LightDir * EPSILON), 1.0);
    EmitVertex();

    // Vertex #4: the ending vertex projected to infinity
    gl_Position = gWVP * vec4(LightDir, 0.0);
    EmitVertex();

    EndPrimitive();
}
```

Projection

Far plane at infinity

$$P = \begin{pmatrix} \frac{1}{\text{aspectRatio} \cdot \tan(\frac{\alpha}{2})} & 0 & 0 & 0 \\ 0 & \frac{1}{\tan(\frac{\alpha}{2})} & 0 & 0 \\ 0 & 0 & \frac{\text{near} + \text{far}}{\text{near} - \text{far}} & \frac{-2 \cdot \text{far} \cdot \text{near}}{\text{near} - \text{far}} \\ 0 & 0 & -1 & 0 \end{pmatrix}$$

Projection

Far plane at infinity

$$P = \begin{pmatrix} \frac{1}{\text{aspectRatio} \cdot \tan(\frac{\alpha}{2})} & 0 & 0 & 0 \\ 0 & \frac{1}{\tan(\frac{\alpha}{2})} & 0 & 0 \\ 0 & 0 & \frac{\text{near} + \text{far}}{\text{near} - \text{far}} & \frac{-2 \cdot \text{far} \cdot \text{near}}{\text{near} - \text{far}} \\ 0 & 0 & -1 & 0 \end{pmatrix}$$

$$\lim_{\text{far} \rightarrow \infty} -\frac{\text{far} + \text{near}}{\text{far} - \text{near}} = \lim_{\text{far} \rightarrow \infty} -\frac{\frac{\text{far}}{\text{far}} + \frac{\text{near}}{\text{far}}}{\frac{\text{far}}{\text{far}} - \frac{\text{near}}{\text{far}}} = -\frac{1 + 0}{1 - 0} = -1$$

Projection

Far plane at infinity

$$P = \begin{pmatrix} \frac{1}{\text{aspectRatio} \cdot \tan(\frac{\alpha}{2})} & 0 & 0 & 0 \\ 0 & \frac{1}{\tan(\frac{\alpha}{2})} & 0 & 0 \\ 0 & 0 & \frac{\text{near} + \text{far}}{\text{near} - \text{far}} & \frac{-2 \cdot \text{far} \cdot \text{near}}{\text{near} - \text{far}} \\ 0 & 0 & -1 & 0 \end{pmatrix}$$

$$\lim_{\text{far} \rightarrow \infty} -\frac{\text{far} + \text{near}}{\text{far} - \text{near}} = \lim_{\text{far} \rightarrow \infty} -\frac{\frac{\text{far}}{\text{far}} + \frac{\text{near}}{\text{far}}}{\frac{\text{far}}{\text{far}} - \frac{\text{near}}{\text{far}}} = -\frac{1 + 0}{1 - 0} = -1$$

$$\lim_{\text{far} \rightarrow \infty} -\frac{2 \cdot \text{far} \cdot \text{near}}{\text{far} - \text{near}} = \lim_{\text{far} \rightarrow \infty} -\frac{\frac{2 \cdot \text{far} \cdot \text{near}}{\text{far}}}{\frac{\text{far}}{\text{far}} - \frac{\text{near}}{\text{far}}} = -\frac{2 \cdot \text{near}}{1 - 0} = -2 \cdot \text{near}$$

Projection

Far plane at infinity

$$P_{inf} = \begin{pmatrix} \frac{1}{\text{aspectRatio} \cdot \tan(\frac{\alpha}{2})} & 0 & 0 & 0 \\ 0 & \frac{1}{\tan(\frac{\alpha}{2})} & 0 & 0 \\ 0 & 0 & -1 & -2 \cdot \text{near} \\ 0 & 0 & -1 & 0 \end{pmatrix}$$

Shadow volume

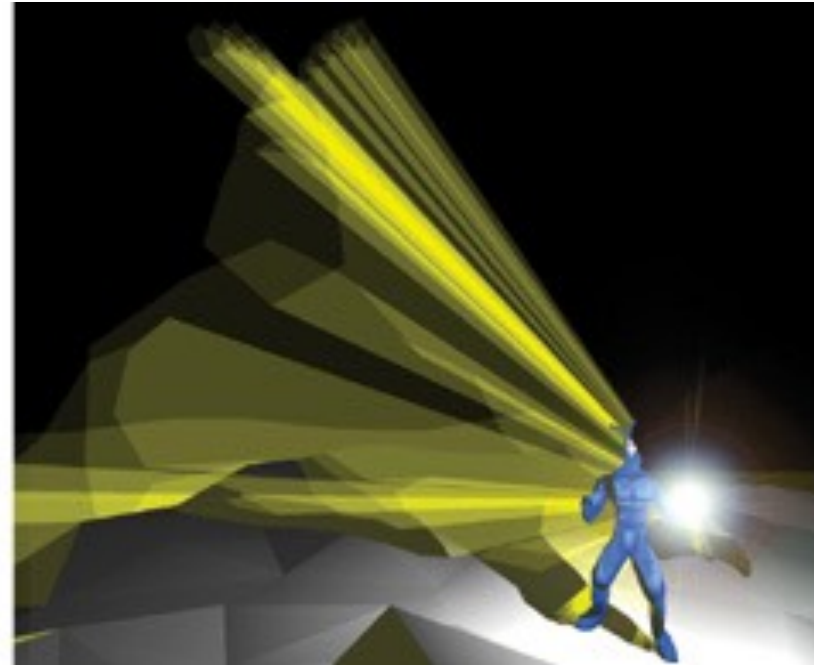

Shadow volume

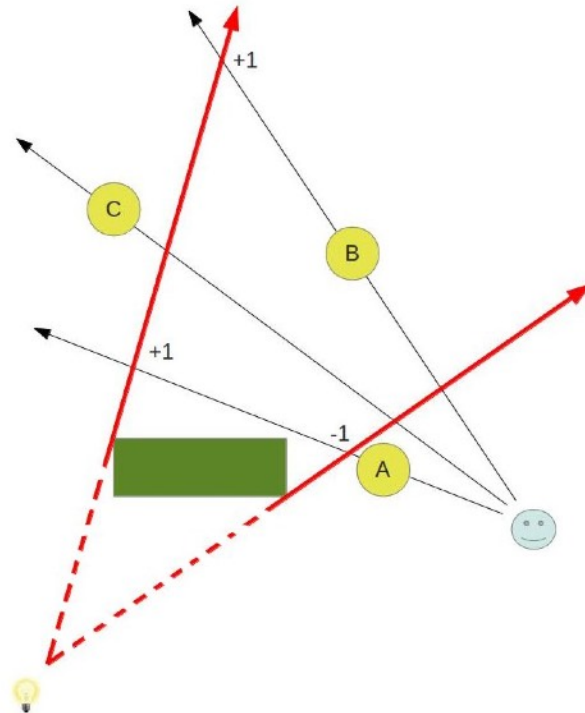

- Trace rays
 - Ray enters volume
 - Increase counter
 - Ray exits volume
 - Decreases counter
- Shadow: counter different than zero

Point P is in shadow if and only if there were more entering intersections than exiting intersections along a ray to infinity.

Shadow volume

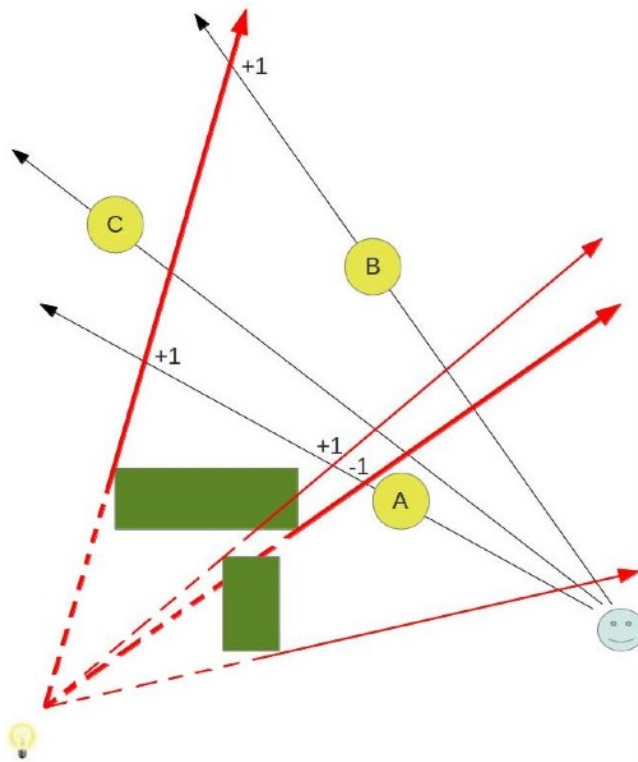

Point P is in shadow if and only if there were more entering intersections than exiting intersections along a ray to infinity.

- Trace rays
 - Ray enters volume
 - Increase counter
 - Ray exits volume
 - Decreases counter
- Shadow: counter different than zero

Shadow volume

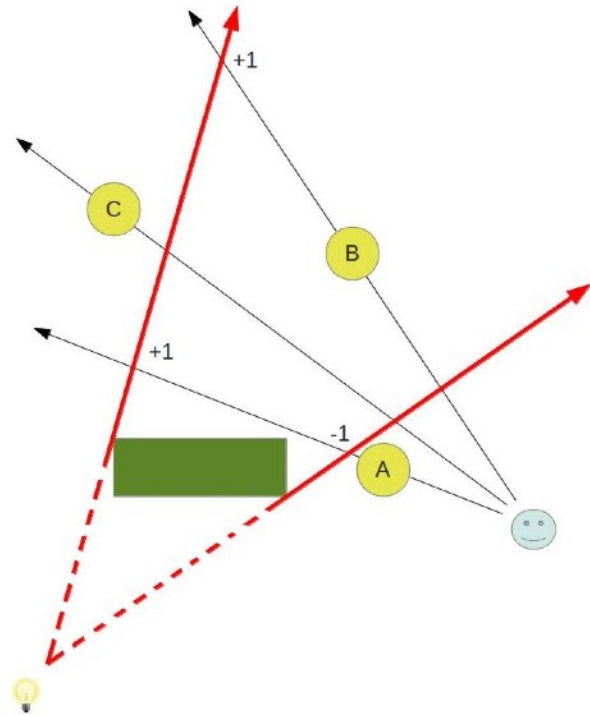

- For each object, determine its shadow volume
- Render back facing polygons of volumes into stencil buffer
 - Depth test fail: increment
- Render front facing polygons of volume into stencil buffer
 - Depth test fail: decrement

Point P is in shadow if and only if there were more entering intersections than exiting intersections along a ray to infinity.

Shadow volume

- Advantages
 - Self-shadowing
 - Everything can shadow everything, including self
- Disadvantages
 - Silhouette computation required
 - Slow on scenes with polygons with large number of triangles



Comparison

- Shadow Volumes:
 - Pros: accurate hard shadows
 - Slower, rasterization heavy
- Shadow Maps:
 - Pros: Fast, supports soft shadows
 - Cons: high memory usage, aliasing